



# **IP Phone Primer**

***Partner Quick Setup Guide (Version 2.1)***

Updated on April 16, 2005

## Contents

1. The IP Phone Primer .....	1
2. Phone Setup .....	2
3. Keypad Legend .....	4
4. Setting the account and PIN.....	4
5. Setting the modem for dial up mode (MODEM) .....	5
6. Setting for Static LAN .....	6
7. Setting for DHCP .....	6
8. Setting for PPPoE (DSL).....	7
9. Checking your account balance.....	8
10. Making your first phone call.....	8
11. Recharging your account.....	8

### **Button Legend**

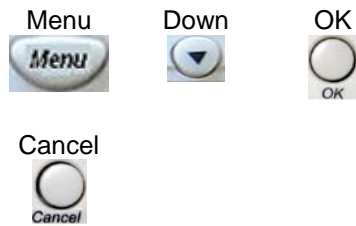

# 1. The IP Phone Primer

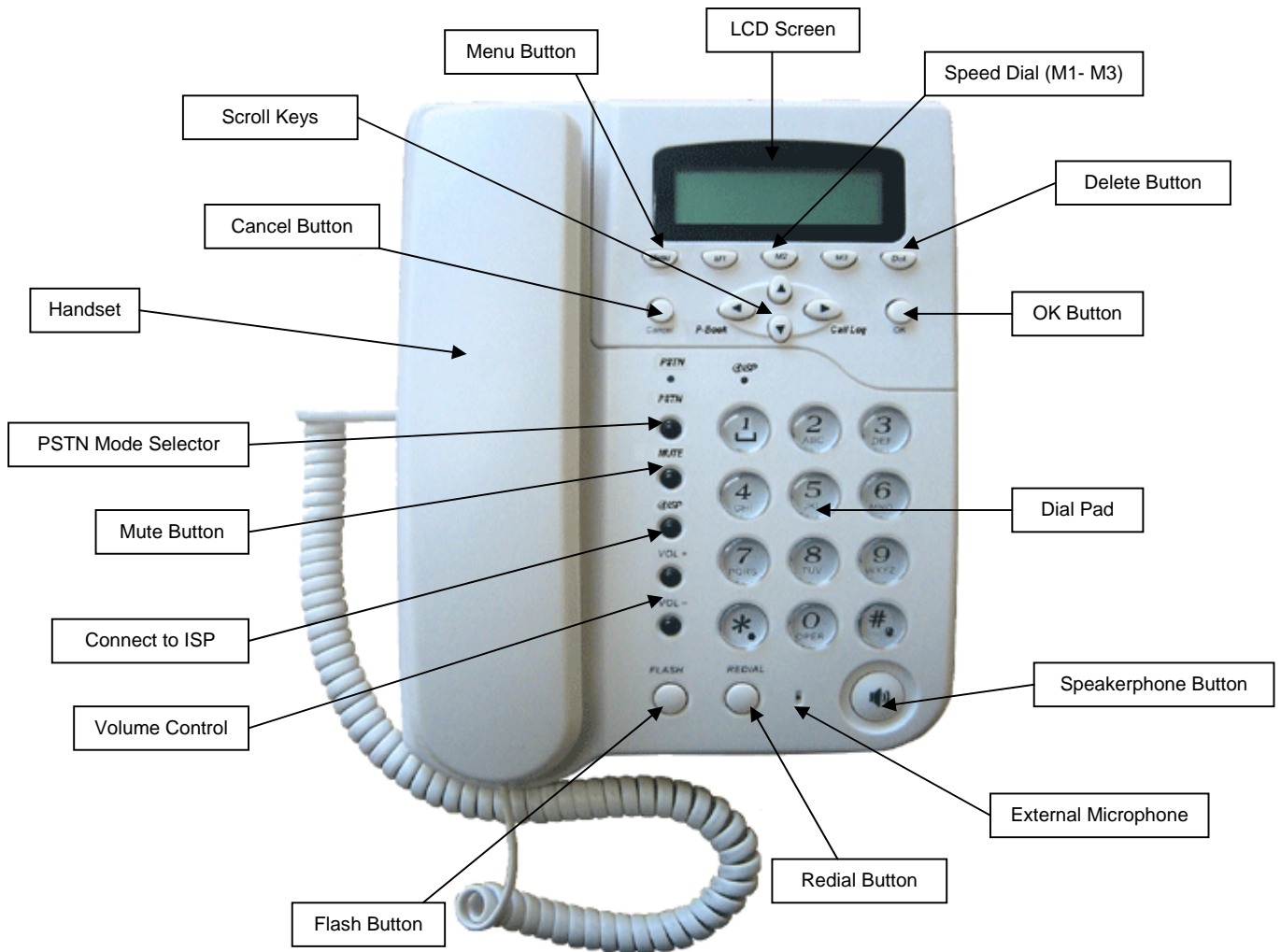

## 2. Phone Setup

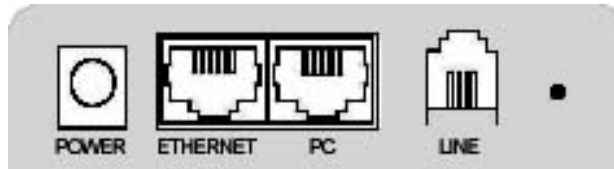

- **POWER** – Plug in the adaptor cable into this port.

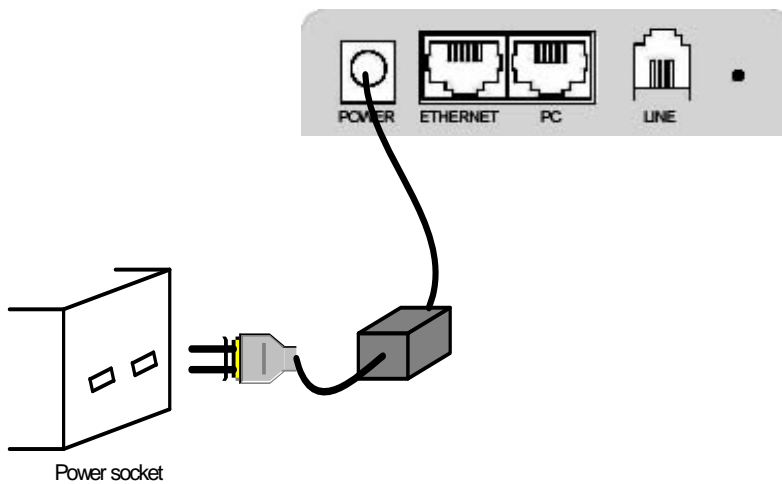

- **ETHERNET** – Use for broadband connection or LAN environment.

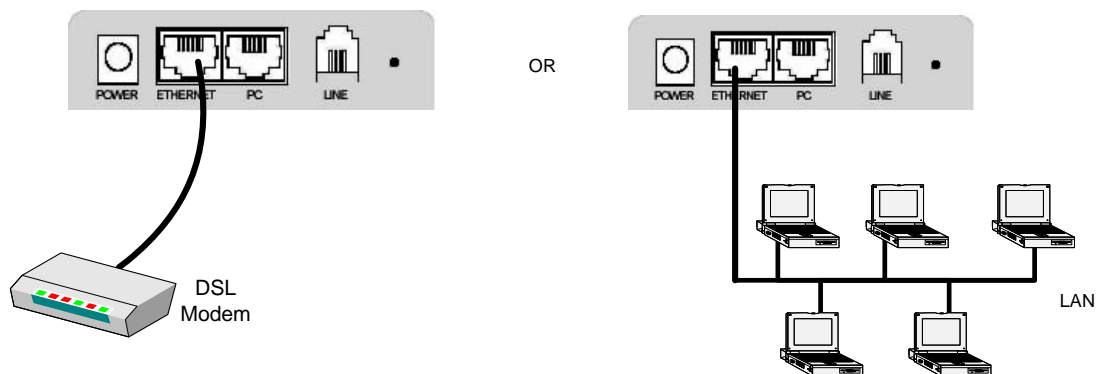

- **PC (optional)** – Use if you wish to use the IP Phone as a router.

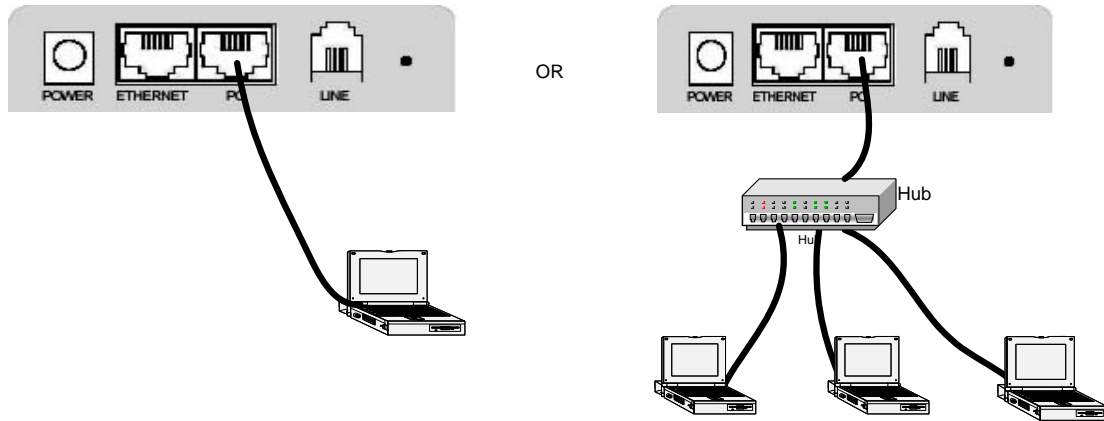

- **LINE** – Using the phone as a normal PSTN phone or using Dial up for the Internet connection. Plug in the phone line into this port

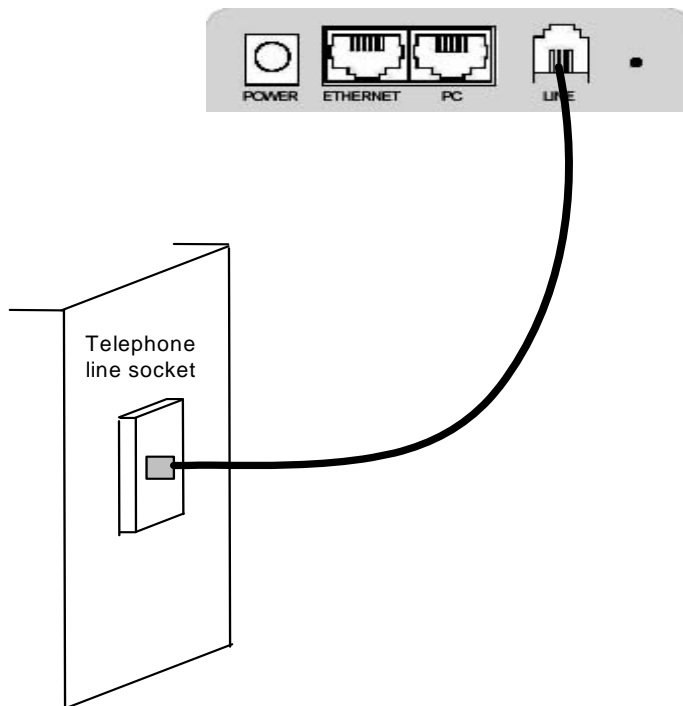

### 3. Keypad Legend

Key	MODE 1 (e) default	MODE 2 (E)	MODE 3 (1)	MODE 4 (#)
1			1	space
2	abc	ABC	2	
3	def	DEF	3	
4	ghi	GHI	4	
5	jkl	JKL	5	
6	mno	MNO	6	
7	pqrs	PQRS	7	
8	tuv	TUV	8	
9	wxyz	WXYZ	9	
0			0	#@*()<> etc

On the top row of the LCD you will see, either 'e', 'E', '1' or '#', each indicating the character input mode. Use the Menu button to change from one mode to another

### 4. Setting the account and PIN

1. Press the **Menu** button.
2. Using the scroll **down** button, scroll to "**5. SETUP**", press the **OK** button to select.
3. Enter **password "0000"**, and press the **OK** button to confirm.
4. Scroll to "**6. Account**" and press **OK**.
5. Select "**1. Account No.**" and press **OK**.
6. Enter your **Account Number**, "xxxxxxxxxxx" and press **OK**.
7. Scroll to "**2. Pin Code**" and press **OK**.
8. Enter your **6 digit Pin code**, "xxxxxx" and press **OK**.
9. To get exit back to the main screen, press **Cancel** three times.

\* Press **Cancel** to exit or cancel at anytime.

## 5. Setting the modem for dial up mode (MODEM)

1. Press the **Menu** button.
2. Using the scroll **down** button, scroll to “**5. SETUP**”, press the **OK** button to select.
3. Enter **password** “**0000**”, and press the **OK** button to confirm.
4. Select “**3. Modem**” and press **OK**.
5. Select “**1: profile1**” and press **OK**.
6. Select “**2.Tel [710]**” and press **OK**.
7. Enter ISP **dial up telephone number**, “xxxxxxx” and press **OK**.
8. Select “**3. ID**” and press **OK**.
9. Enter **login id**<sup>^</sup>, **ID** “xxxxxxx” and press **OK**.
10. Select “**4. PWD**” and press **OK**.
11. Enter **password, PWD**<sup>^</sup> “xxxxxxx” and press **OK**. The dial up setting is all stored.
12. To exit back to the main screen, press **Cancel** three times.
13. To start the dial up connection, press the **@DISP** button.

\* Press **Cancel** to exit or cancel at anytime.

<sup>^</sup> Refer to Section 3(Keypad Legend) for entering numerical, upper case, lower case or symbols

## 6. Setting for Static LAN

1. Press the **Menu** button.
2. Using the scroll **down** button, scroll to “**5. SETUP**”, press the **OK** button to select.
3. Enter **password “0000”**, and press the **OK** button to confirm.
4. Select “**2. Network**” and press **OK**.
5. Select “**2. Mode Select**” and press **OK**.
6. Select “**1. LAN (static)**” and press **OK**.
7. Enter the **IP address** and press **OK**.
8. Enter the **subnet mask** and press **OK**.
9. Enter the **default gateway** and press **OK**.
10. Leave the default DNS as 168.126.63.1 and press **OK**.
11. Select “**YES**” to apply new settings.
12. Select “**YES**” to reboot the system.

*\* Press **Cancel** to exit or cancel at anytime.*

## 7. Setting for DHCP

1. Press the **Menu** button.
2. Using the scroll **down** button, scroll to “**5. SETUP**”, press the **OK** button to select.
3. Enter password “**0000**”, and press the **OK** button to confirm.
4. Select “**2. Network**” and press **OK**.
5. Select “**2. Mode Select**” and press **OK**.

6. Select “**2. Network**” and press **OK**.
7. Select “**2. DHCP**” and press **OK**.
8. Select “**YES**” to confirm selection.
9. Select “**YES**” to reboot system.

*\* Press **Cancel** to exit or cancel at anytime.*

## 8. Setting for PPPoE (DSL)

1. Press the **Menu** button.
2. Using the scroll **down** button, scroll to “**5. Setup**”, press the **OK** button to select.
3. Enter **password** “**0000**”, and press the **OK** to select.
4. Select “**2. Network**” and press **OK** .
5. Select “**2. Mode Select**” and press **OK**.
6. Select “**3. PPPoE**” and press **OK**.
7. Enter your **PPPoE ID**<sup>^</sup> , “xxxxxxxx” and press **OK**.
8. Enter **password PWD**<sup>^</sup>, “xxxxxx” and press **OK**.
9. Select “**YES**” to apply new setting, “**No**” to cancel.
10. Select “**YES**” to reboot system.

*\* Press **Cancel** to exit or cancel at anytime.*

*<sup>^</sup> Refer to Section 3(Keypad Legend) for entering numerical, upper case, lower case or symbols*

## 9. Checking your account balance

1. Press the **Menu** button.
2. Using the scroll **down** button, select “**4. Account Balance**” and press **OK** to select.

## 10. Making your first phone call

### How to make your first off-net call

1. Pick up the handset.
2. Dial your friend’s telephone number followed by the **#** key. The dialing sequence is “*country code + area code (if any) + phone number + #*”

### How to make your first on-net call

1. Pick up the handset.
2. Dial your friend’s 12 digit on-net number (698 xxx xxxx) follow by the **#** key.

## 11. Recharging your account

Account recharging can only be done through the fund transfer interface. It is a web-based application and not one that is incorporated into the phone hardware. Please contact your Sales representative for more information.